



**Thick Film High Power Chip Resistors  
(RMH series standard Halogen-Free)**

Document No.	TRMH-XX0S001N
Revise Date	2023/04/17
page number	1/13

**1. Scope :**

This specification applies for the thick film high power chip resistors made by TA-I.

**2. Construction :**

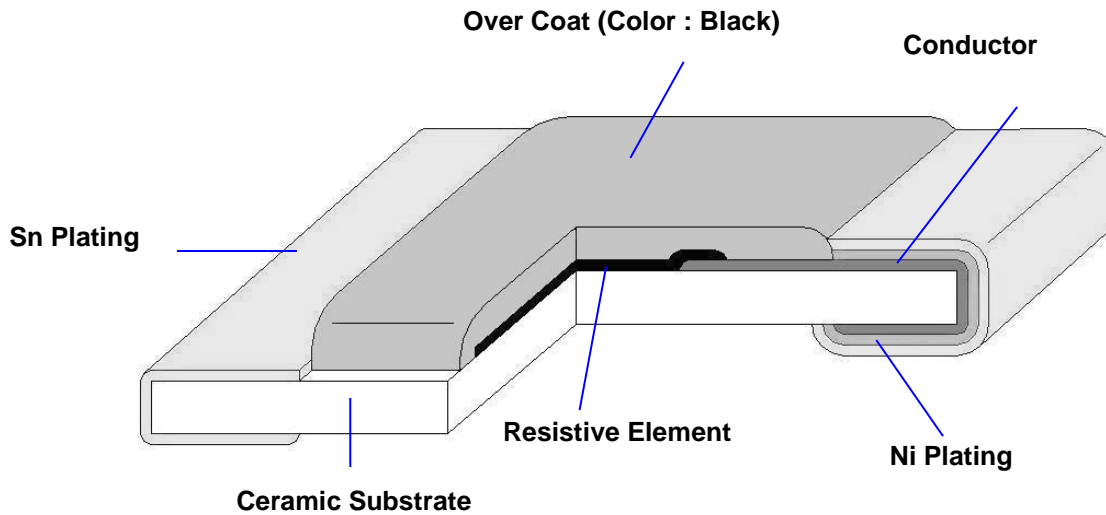

**3.Type Designation :**

**RMH**

**10**

**J**

**T**

**103**

Product Code

Size

Tolerance

Packaging

Nominal

RMH : High Power

Power Rating

Resistance

Chip Resistor

04-0402(1005)	1/8W	J-±5%	T- Paper Tape	3 digits, e.g., : (E-24) 103 = 10kΩ  4 digits, e.g., : (E-96) 1540 = 154Ω 43R2 = 43.2Ω
06-0603(1608)	1/5W	F-±1%	E- Emboss Tape	
10-0805(2012)	1/4W	D-±0.5%		
12-1206(3216)	1/2W			
20-2010(5025)	1W			
25-2512(6432)	2W			



#### 4. Dimensions :

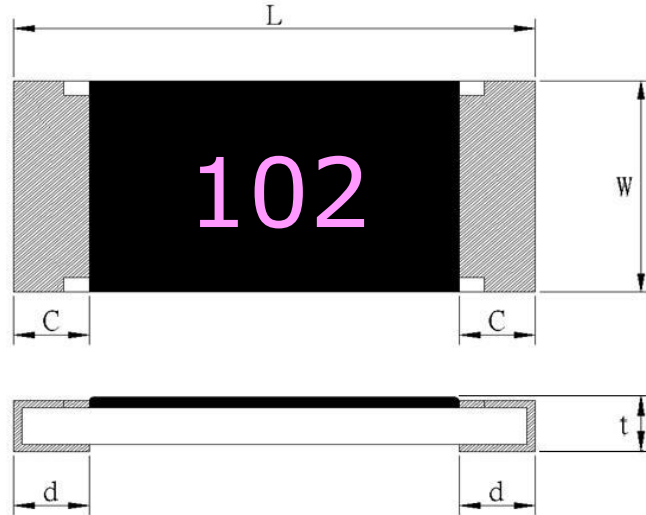

UNIT: mm

Type	L	W	C	d	t
RMH04	1.00 <sup>+0.10</sup> <sub>-0.05</sub>	0.50±0.05	0.20±0.10	0.25±0.10	0.32±0.05
RMH06	1.60±0.10	0.80±0.10	0.30±0.20	0.30 <sup>+0.2</sup> <sub>-0.1</sub>	0.45±0.10
RMH10	2.00±0.10	1.25±0.10	0.40±0.20	0.40±0.20	0.50±0.10
RMH12	3.10±0.10	1.55±0.10	0.50±0.30	0.40±0.20	0.55±0.10
RMH20	5.00±0.15	2.50±0.15	0.60±0.30	0.50±0.25	0.60±0.10
RMH25	6.30±0.20	3.20±0.20	0.60±0.30	0.50±0.25	0.60±0.10



Thick Film High Power Chip Resistors  
(RMH series standard Halogen-Free)

Document No.	TRMH-XX0S001N
Revise Date	2023/04/17
page number	3/13

### 5. Ratings & Characteristics :

Type	Power Rating at 70°C	Rating Voltage	Max. Working Voltage	Max. Over-Load Voltage	T.C.R (PPM/°C)	Resistance Range(Ω)		
						D(±0.5%) E-96&E-24	F(±1%) E-96&E-24	J(±5%) E-24
RMH04	1/8W	Refer 5.2	50V	100V	±100	100Ω~1MΩ	100Ω~1MΩ	100Ω~1MΩ
					±200	10Ω ≤ R < 100Ω	10Ω ≤ R < 100Ω	10Ω ≤ R < 100Ω
					+400 -200		1Ω ≤ R < 10Ω	1Ω ≤ R < 10Ω
RMH06	1/5W	Refer 5.2	50V	100V	±100	10Ω~1MΩ	10Ω-1MΩ	10Ω-1MΩ
					+400 -200		1Ω ≤ R < 10Ω	1Ω ≤ R < 10Ω
RMH10	1/4W	Refer 5.2	150V	300V	±100	10Ω~1MΩ	10Ω-1MΩ	10Ω-1MΩ
					+400 -200		1Ω ≤ R < 10Ω	1Ω ≤ R < 10Ω
RMH12	1/2W	Refer 5.2	200V	400V	±100	10Ω~1MΩ	10Ω-1MΩ	10Ω-1MΩ
					+400 -200		1Ω ≤ R < 10Ω	1Ω ≤ R < 10Ω
RMH20	1W	Refer 5.2	200V	400V	±100	10Ω~1MΩ	10Ω-1MΩ	10Ω-1MΩ
					+400 -200		1Ω ≤ R < 10Ω	1Ω ≤ R < 10Ω
RMH25	2W	Refer 5.2	200V	400V	±100	10Ω~1MΩ	10Ω-1MΩ	10Ω-1MΩ
					+400 -200		1Ω ≤ R < 10Ω	1Ω ≤ R < 10Ω

Operating Temp(°C): -55°C ~ +155°C

Note : Except for the above standardized products, we also provide the customized products.



### 5.1 Derating Curve :

For resistors operated at ambient temperature over 70°C , power rating shall be derated in accordance with figure 1.

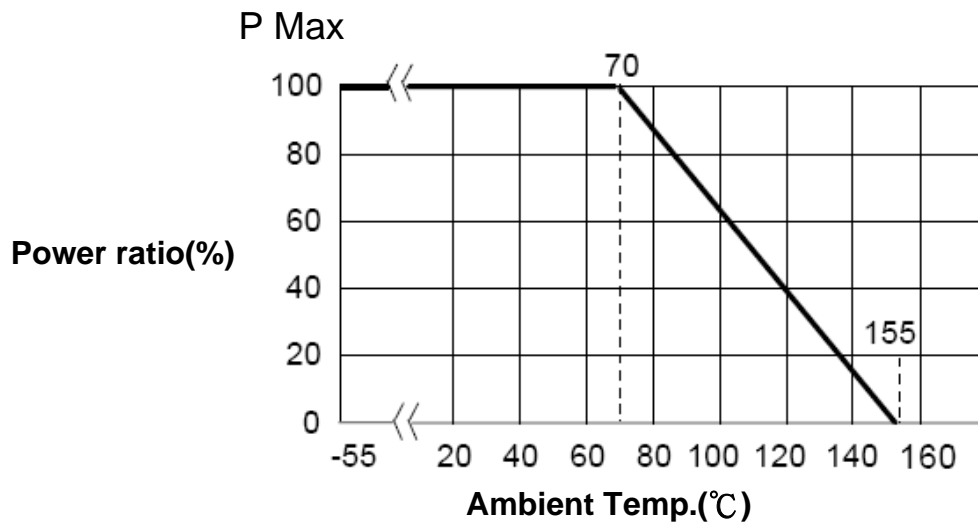

Figure 1

### 5.2 Rated Voltage :

The rated voltage is calculated by the following formula:

$$E = \sqrt{P * R}$$

$E$ =Rated Voltage(V)  
 $P$ =Rated Power(W)  
 $R$ =Resistance Value( $\Omega$ )

E.G. : What is RMH06JT102 the rated voltage ?

RMH06JT102 P:1/5W ; R:102 = 1K $\Omega$  = 1000 $\Omega$

$$E = \sqrt{0.2(W) * 1000(\Omega)} = 14.14 (V)$$



**Thick Film High Power Chip Resistors  
(RMH series standard Halogen-Free)**

Document No.	TRMH-XX0S001N
Revise Date	2023/04/17
page number	5/13

**6. Reliability Tests :**

Test Items	Reference standard	Condition of Test	Test Limits $\Delta R$
Temperature Coefficient of Resistance	IEC60115-1-4.8 JIS-C5201-1-4.8	-55~ +125 °C	Refer 5.0
Short Time Overload	IEC60115-1-4.13 JIS-C5201-1-4.13	2.5 X rated voltage for 5 sec	$\pm(1\% + 0.05 \Omega)$
Intermittent Overload	IEC60115-1-4.39 JIS-C5201-1-4.39	2.5X rated voltage or Max Overloading voltage ,1sec "ON" , 25sec "OFF" , 10000 cycles	$\pm (5.0\% + 0.1 \Omega)$
Endurance (Load Life)	IEC60115-1-4.25.1 JIS-C5201-1-4.25.1	1000 hours at rated voltage, 70°C , 1.5hours "ON" , 0.5hour "OFF"	0402: $\pm(3.0\%+0.1 \Omega)$ 0.5%,1%: $\pm(1.0\%+0.05 \Omega)$ 5%: $\pm(3.0\%+0.1 \Omega)$
Load Life with Humidity	IEC60115-1-4.24 JIS-C5201-1-4.24	1000 hours at rated voltage , 40 $\pm$ 2°C , 90~95% RH 1.5hours "ON" , 0.5hour "OFF"	0402: $\pm(3.0\%+0.1 \Omega)$ 0.5%,1%: $\pm(1.0\%+0.05 \Omega)$ 5%: $\pm(3.0\%+0.1 \Omega)$
Rapid Change of Temperature	IEC60115-1-4.19 JIS-C5201-1-4.19	-55°C (30 min. ) / +155 °C(30 min. ) 5 cycles	0.5%,1%: $\pm(0.5\%+0.05 \Omega)$ 5%: $\pm(1.0\%+0.05 \Omega)$
Solderability	IEC60115-1-4.17 JIS-C5201-1-4.17	245 $\pm$ 5°C solder, 2 $\pm$ 0.5 sec dwell. Solder : Sn96.5 / Ag3.0 / Cu0.5	At least 95% of surface area of electrode shall be covered with new solder.
Robustness of Termination (Bending)	IEC60115-1-4.33 JIS-C5201-1-4.33	3mm deflection 2mm deflection (RMH20,25)	0.5%,1%: $\pm(0.5\%+0.05 \Omega)$ 5%: $\pm(1.0\%+0.05 \Omega)$
Dielectric Withstanding Voltage (Voltage Proof)	IEC60115-1-4.7 JIS-C5201-1-4.7	Applying voltage : 0402 & 0603 : 300V The other 500V for a minute.	No abnormalities such as flashover, burning dielectric breakdown shall appear.
Insulation Resistance	IEC60115-1-4.6 JIS-C5201-1-4.6	Applying voltage 100V for 1 minute.	$\geq 1G \Omega$
Resistance to Dry Heat	IEC60115-1-4.23.2 JIS-C5201-1-4.23.2	155 $\pm$ 5°C for 96 $\pm$ 4Hrs	0.5%,1%: $\pm(1.0\%+0.05 \Omega)$ 5%: $\pm(2.0\%+0.1 \Omega)$
Resistance to Solder Heat	IEC60115-1-4.18 JIS-C5201-1-4.18	270 $\pm$ 5°C solder , 10 $\pm$ 1 sec dwell .	0.5%,1%: $\pm(0.5\%+0.05 \Omega)$ 5%: $\pm(1.0\%+0.05 \Omega)$

Note\* : RCWV : Rated continuous working voltage .



## 7. Marking :

### 7.1 ±5%(E24) : RMH06 / RMH10 / RMH12 / RMH20 / RMH25

Resistance value is expressed by 3 digits, the first two digits represent the significant figures of nominal resistance value in  $\Omega$ , and the third digit represents exponent for base of 10.

E.G. :, 102 =  $10 \times 10^2 = 1000 \Omega = 1K \Omega$



### 7.2 ±0.5% , ±1% (E96) : RMH10 / RMH12 / RMH20/ RMH25

Resistance value is expressed by 4 digits , the first three digits represent the significant figures of nominal resistance value in  $\Omega$ , and the fourth digit represents exponent for base of 10.

E.G. : 1000 =  $100 \times 10^0 = 100 \Omega$



### 7.3 ±0.5% , ±1% ( E96): RMH06

When the marking space is too small in such small-sized resistors as RMH06, the marking can not made by 4 digits and may be made by two digits combined with one English capital.

**Symbol for E96 series nominal resistance value**

Symbol	E96	Symbol	E96	Symbol	E96	Symbol	E96
01	100	25	178	49	316	73	562
02	102	26	182	50	324	74	576
03	105	27	187	51	332	75	590
04	107	28	191	52	340	76	604
05	110	29	196	53	348	77	619
06	113	30	200	54	357	78	634
07	115	31	205	55	365	79	649
08	118	32	210	56	374	80	665
09	121	33	215	57	383	81	681
10	124	34	221	58	392	82	698
11	127	35	226	59	402	83	715
12	130	36	232	60	412	84	732
13	133	37	237	61	422	85	750
14	137	38	243	62	432	86	768
15	140	39	249	63	442	87	787
16	143	40	255	64	453	88	806
17	147	41	261	65	464	89	825
18	150	42	267	66	475	90	845
19	154	43	274	67	487	91	866



Thick Film High Power Chip Resistors  
(RMH series standard Halogen-Free)

Document No.	TRMH-XX0S001N
Revise Date	2023/04/17
page number	7/13

20	158	44	280	68	499	92	887
21	162	45	287	69	511	93	909
22	165	46	294	70	523	94	931
23	169	47	301	71	536	95	953
24	174	48	309	72	549	96	976

Symbol for multipliers

Symbol	A	B	C	D	E	F	G	H	X	Y	Z
multipliers	10 <sup>0</sup>	10 <sup>1</sup>	10 <sup>2</sup>	10 <sup>3</sup>	10 <sup>4</sup>	10 <sup>5</sup>	10 <sup>6</sup>	10 <sup>7</sup>	10 <sup>-1</sup>	10 <sup>-2</sup>	10 <sup>-3</sup>

E.G : 01A = 100×10<sup>0</sup> = 100Ω



Notes :

When the resistance value is not in the list of E96 , 3 digitals with underline in E-24 series is used as mark .

E.G.: 0603 , 120Ω , 1% Marking is 121



7.4 RMH04 :

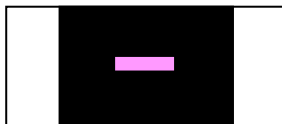



## 8. Taping & Reel :

### 8.1 Taping Dimensions

#### 8.1.1 4 mm pitch paper:

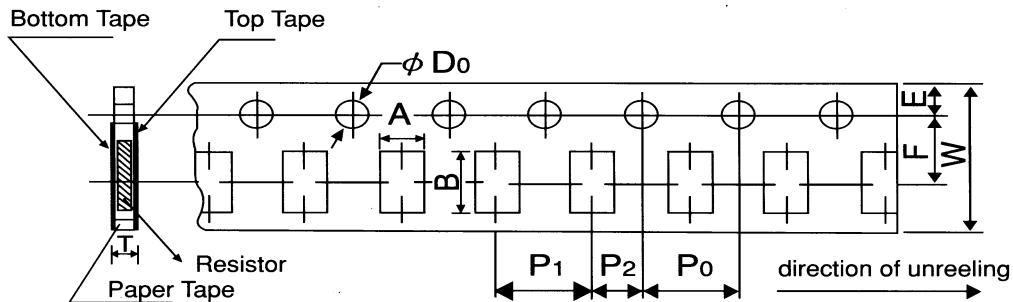

Packing	Type	A	B	W	F	E	P <sub>1</sub>	P <sub>2</sub>	P <sub>0</sub>	D <sub>0</sub>	T
Paper	RMH06	1.1±0.1	1.9±0.1	8.0±0.2	3.5±0.05	1.75±0.1	4.0±0.1	2.0±0.05	4.0±0.1	φ 1.5	0.64±0.1
	RMH10	1.6±0.15	2.4±0.2								0.84±0.1
	RMH12	2.0±0.15	3.6±0.2								

#### 8.1.2 Taping Dimensions 2 mm pitch paper :

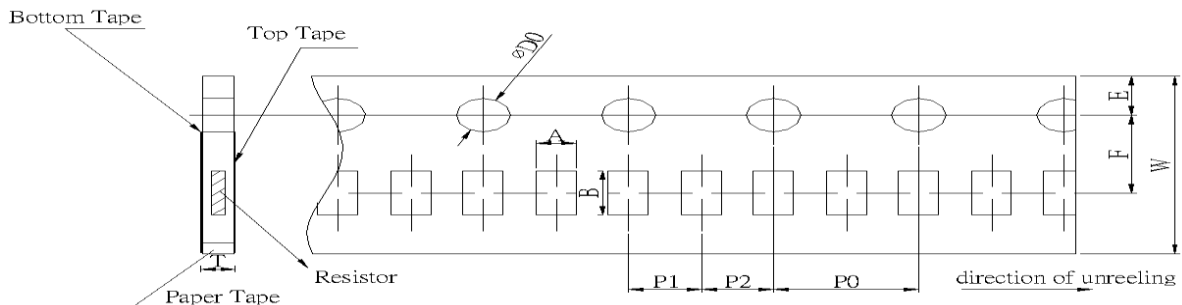

Packing	Type	A	B	W	F	E	P <sub>1</sub>	P <sub>2</sub>	P <sub>0</sub>	D <sub>0</sub>	T
Paper	RMH04	0.7±0.05	1.2±0.05	8.0±0.2	3.5±0.05	1.75±0.1	2.0±0.1	2.0±0.1	4.0±0.1	φ 1.5	0.45±0.1



Thick Film High Power Chip Resistors  
(RMH series standard Halogen-Free)

Document No.	TRMH-XX0S001N
Revise Date	2023/04/17
page number	9/13

8.1.3 4 mm pitch Emboss :

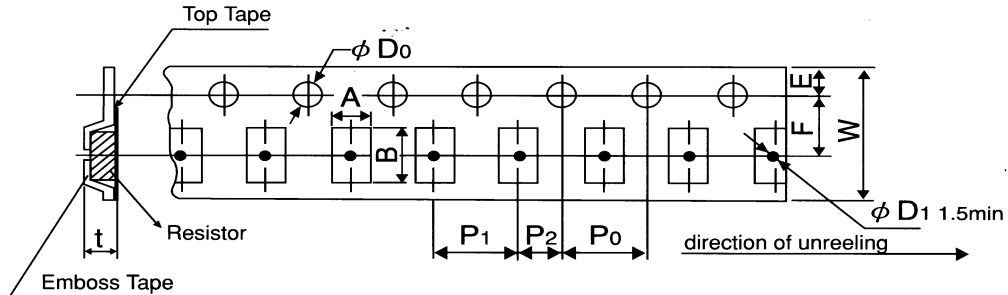

Packing	Type	A	B	W	F	E	P <sub>1</sub>	P <sub>2</sub>	P <sub>0</sub>	D <sub>0</sub>	T
Emboss	RMH20	2.8±0.2	5.3±0.2	12.0±0.2	5.5±0.05	1.75±0.1	4.0±0.1	2.0±0.05	4.0±0.05	φ 1.5	+0.1
	RMH25	3.6±0.2	6.9±0.2								-0

UNIT: PCS

Type	Size	Paper Tape				Emboss Plastic Tape 4 mm pitch
		4 mm pitch		2 mm pitch		
		178mm/R	250mm/R	178mm/R	250mm/R	
RMH	04			10000	20000	
RMH	06	5000	10000			
RMH	10	5000	10000			
RMH	12	5000	10000			
RMH	20					4000
RMH	25					4000

8.3 Reel Specifications:

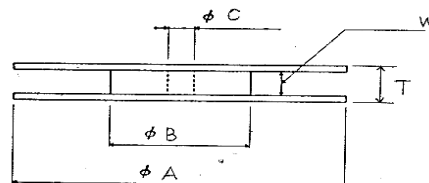
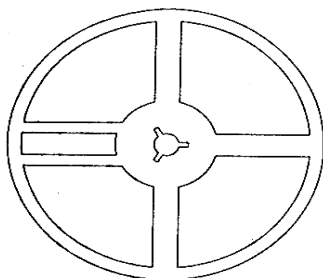

UNIT: mm

Type	φ A	φ B	φ C	W	T
RMH04/06/10/12	178.0 ± 2.0	60.0 ± 1.0	13.0 ± 1.0	9.0 ± 1.0	11.5 ± 1.0
RMH20/25				13.0 ± 1.0	15.5 ± 1.0



# Thick Film High Power Chip Resistors (RMH series standard Halogen-Free)

Document No.	TRMH-XX0S001N
Revise Date	2023/04/17
page number	10/13

### 8.4. Peel –off force :

Peel –off force of paper and blister tape is in accordance with “JIS-C5202 ”  
that is , 0.1 to 0.7 N at a peel-off speed of 300 mm / minute.

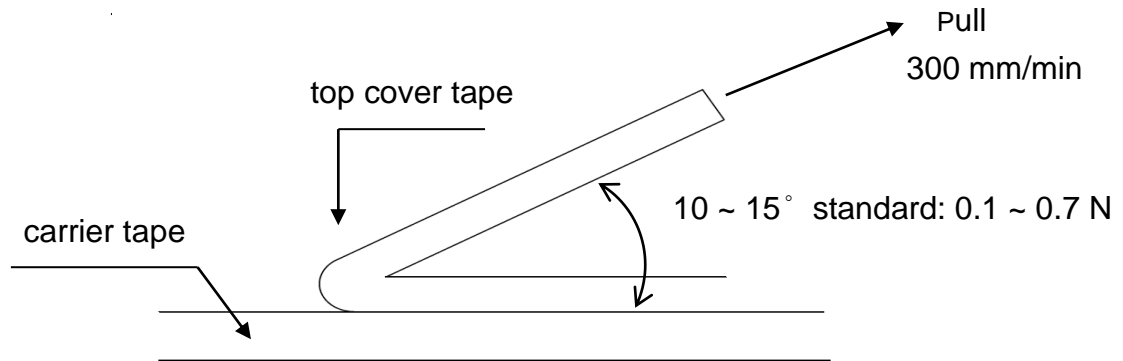

### 9. Label :

#### 9.1 Manufacture Label :

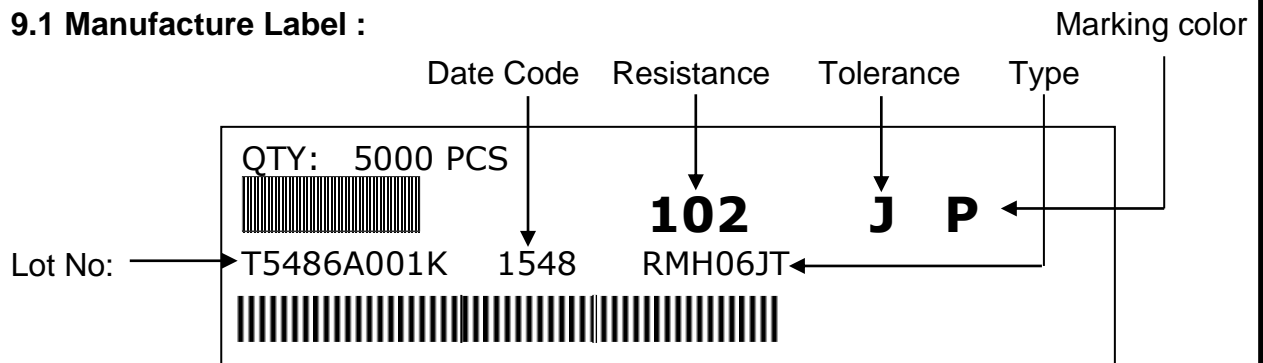

#### 9.2 Customer Label ( By customer request ):

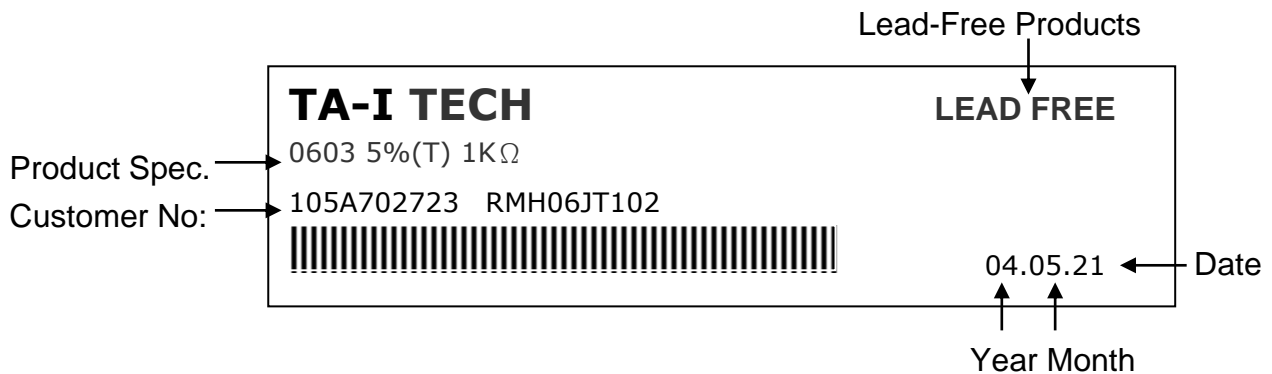



### 10. Recommended land patterns :

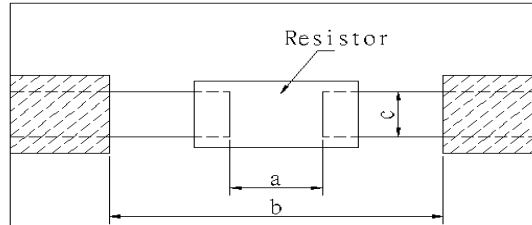

Type	Size	Land pattern	Dimension ( mm )		
			a	b	c
RMH	04 (0402)		0.50~0.6	1.4~1.6	0.4~0.6
RMH	06 (0603)		0.7~0.9	2.0~2.2	0.8~1.0
RMH	10 (0805)		1.0~1.4	3.2~3.8	0.9~1.4
RMH	12 (1206)		2.0~2.4	4.4~5.0	1.2~1.8
RMH	20 (2010)		3.3~3.7	5.7~6.5	2.3~3.5
RMH	25 (2512)		3.6~4.0	7.6~8.6	2.3~3.5

### 11. Recommend IR – Reflow profile : (solder : Sn96.5 / Ag3 / Cu0.5)

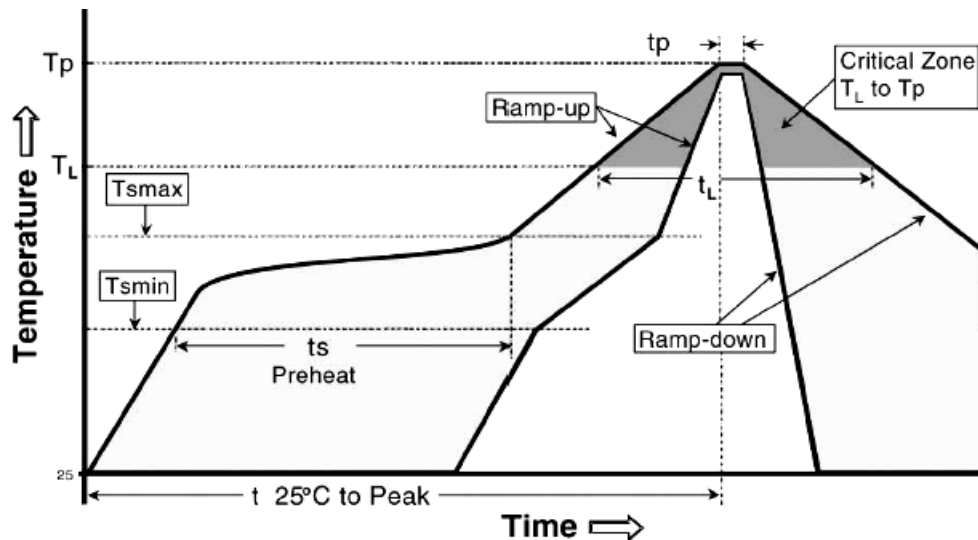

Allowed Re-flow times : 3 times

Remark : To avoid discoloration phenomena of chip on terminal electrodes,  
please use N2 Re-flow furnace.



**Thick Film High Power Chip Resistors  
(RMH series standard Halogen-Free)**

Document No.	TRMH-XX0S001N
Revise Date	2023/04/17
page number	12/13

Profile Feature	Lead (Pb )-Free Assembly
Average ramp-up rate (T <sub>smax</sub> to T <sub>p</sub> )	3°C / second max.
Preheat - Temperature Min (T <sub>smin</sub> ) - Temperature Max (T <sub>smax</sub> ) - Time (T <sub>smin</sub> to T <sub>smax</sub> ) (ts)	150°C 200°C 60 -120 seconds
Time maintained above : - Temperature (T <sub>L</sub> ) - Time (T <sub>L</sub> )	217°C 60-150 seconds
Peak Temperature (T <sub>p</sub> )	260°C
Time within $\begin{matrix} +0 \\ -5 \end{matrix}$ °C of actual Peak Temperature (tp) <sup>2</sup>	10 seconds
Ramp-down Rate	6°C/second max.
Time 25°C to Peak Temperature	8mimutes max.

**12. Storage Conditions:**

Temperature: 5°C~35°C, Humidity:40%~75%

**13. Shelf Life:**

2 years from manufacturing date.

**14. ECN :**

Engineering Change Notice: The customer will be informed with ECN if there is significant modification on the characteristics and materials described in Approval Sheet.



Thick Film High Power Chip Resistors  
(RMH series standard Halogen-Free)

Document No.	TRMH-XX0S001N
Revise Date	2023/04/17
page number	13/13

**15. Manufacturing Country & City :**

TA-I TECHNOLOGY CO., LTD. ( Taiwan– Tao Yuan )  
Tel: 886-3-3246169 Fax : 886-3-3246167

**Associated companies :**

- (1) FORTUNE TASK RESISTOR FACTORY ( China – Dongguan )  
Tel : 86-769-8339-4790~3 Fax : 86-769-8339-4794
- (2) TA-I TECHNOLOGY (DONGGUAN) CO., LTD. ( China –Dongguan )  
Tel : 86-769-8339-4790~3 Fax : 86-769-8339-4794
- (3) TA-I TECHNOLOGY ( SU ZHOU ) CO., LTD. ( China – Su Zhou)  
Tel :86- 512-63457879 Fax : 86-512-63457869
- (4) TAI OHM ELECTRONICS ( M ) SDN. BHD. ( Malaysia – Penang )  
Tel :604- 3900480 Fax : 604-3901481
- (5) P.T.TAI ELECTRONICS Indonesia ( Indonesia – Jakarta )  
Tel :62-21-89830123 Fax : 62-21-89830703